

# COMMERCIAL INGROUND **VERSION 3.0**

## Specifications

**Model E-LOOP:** EL00IG & EL00IG-RAD

**Frequency:** 433.39 MHz.

**Security:** 128-bit AES encryption.

**Range:** up to 50 metres.

**Battery life:** up to 6-10 years.

**Battery type:** 14500 mA battery.

**Transmitting power:** <10mW.



### Installation Warnings



The e-LOOP should be installed in a location that is always visible. Do not place the e-LOOP in a dip or area where snow or water can sit. Keep e-LOOP central in the driveway so as it passes directly underneath the vehicles.

DISCLAIMER: UNITS WITH THE PRESENCE FEATURE IS NOT TO BE USED AS A SOLE SAFETY DEVICE & SHOULD BE USED IN CONJUNCTION WITH STANDARD GATE SAFETY PRACTICES.

## Installation in 3 simple steps

### **STEP 1:** Coding e-LOOP into e-Trans 50

#### Short-range coding e-LOOP with magnet

1. Power up the e-TRANS 50, then press and release the CODE button. The blue LED on the e-TRANS 50 will light up, now place the magnet on the CODE recess on the e-Loop, the yellow LED will flash, and the blue LED on the e-TRANS 50 will flash 3 times. The systems are now paired, and you can remove the magnet.

**NOTE:** For coding e-TRANS-200 LCD transceivers, refer to the e-TRANS-200 manual.

#### Long-range coding e-LOOP with magnet

1. Power up the e-TRANS 50, then place the magnet on the code recess of the e-Loop, the yellow code LED will flash once now remove magnet and the LED come on solid, now walk over to the e-TRANS 50 and press and release the CODE button, the yellow LED will flash and the blue LED on the e-Trans 50 will flash 3 times, after 15 seconds the e-loop code LED will turn off.

**Safety instructions:** Before proceeding with the product's installation, check that all the materials are in good working order and suited to the intended applications. Warning! – Exhausted batteries contain polluting substances; therefore they may not be disposed of together with unsorted household waste. They must be disposed of separately according to the regulations locally in force.

**Disposal:** The packaging must be disposed of in the local recyclable containers. According to the European Directive 2002/96/EC on waste electrical equipment, this device must be properly disposed of, after usage in order to ensure a recycling of the materials used. Old accumulators and batteries may not be disposed of in the household waste, since they contain pollutants and must be properly disposed of in municipal collection points or in the containers of the dealer provided. Country-specific regulations must be observed.

## STEP 2: Fitting e-LOOP

(Refer to diagram below)

1. Drill (89-92mm) hole 65-70mm deep. Ensure the hole is clean and dry before fitting.
2. Measure down before inserting the e-LOOP to ensure it will fit flush with the driveway surface, then pour sikaflex or similar compound into the base of hole.
3. Insert the e-LOOP by pushing down until flush with driveway surface.

**NOTE: Ensure e-LOOP is fitted in a well drained area, as water over the e-LOOP can effect the radar detection system.**

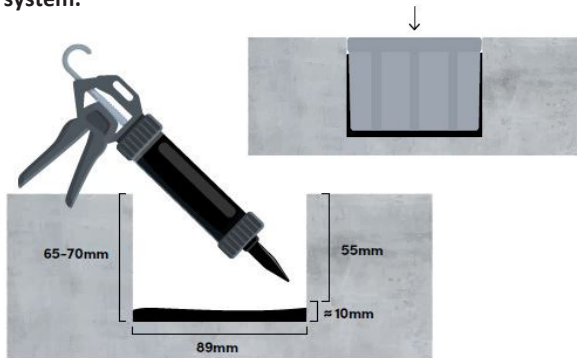

PLACING  
MAGNET INTO  
BUTTON RECESS.

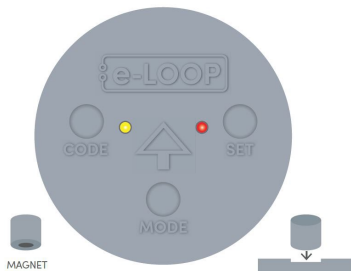

### Uncalibrate the e-LOOP

Place the magnet into the SET button recess until red LED flashes 4 times, e-LOOP is now uncalibrated.

### Changing mode using a magnet (ELOOIG-RAD only)

Note: e-loop comes preset in presence mode.

1. Place a magnet on the MODE recess until the yellow starts LED flashing indicating presence mode, to change to exit mode place the magnet on the SET recess, the red LED will start flashing, to change to parking mode place the magnet on the MODE recess, the Yellow LED will come on solid.
2. Wait 5 seconds until all LED's flash, we have now entered the confirmation menu, move to Step 3 or wait a further 5 seconds until all LED's flash 3 times to exit menu.
3. **Confirmation mode.**  
Once in the confirmation menu the red LED will be on solid meaning confirmation is not enabled, to enable place magnet on code recess, the yellow LED and red LED will be on, confirmation is now enabled, wait 5 seconds and both LED's will flash 3 times indicating menu has now been exited.

### Parameters that can be altered on EL00IG-RAD (Requires e-Diagnostic Remote or E-Trans-200):

1. Mode is set to PRESENCE but can be changed to EXIT mode. NOTE: do not use presence mode as a personal safety device.
2. Activation detection level
3. X, Y, Z axis sensitivity
4. Radar read time
5. Release trip point
6. Start lens detection range
7. Measure lens detection range
8. Radar trip sensitivity
9. Radar confirm ON/OFF

## STEP 3: Calibrate e-LOOP

1. Move any metal objects away from the e-LOOP.
2. Place magnet into the SET button recess on the e-LOOP until the red LED flashes twice, then remove the magnet.
3. The e-LOOP will take about 5 seconds to calibrate and once complete, the red LED will flash 3 times.

**The system is now ready.**

**NOTE:** After calibration, you may get an error indication.

**ERROR 1:** Low radio range - yellow LED flashes 3 times before red LED flashes 3 times.

**ERROR 2:** No radio connection - yellow and red LED flashes 3 times before red LED flashes 3 times.

Document updated: 27/05/24.

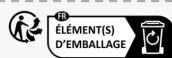

Points de collecte sur [www.quefairedemesdechets.fr](http://www.quefairedemesdechets.fr)